

CASTLOADERS

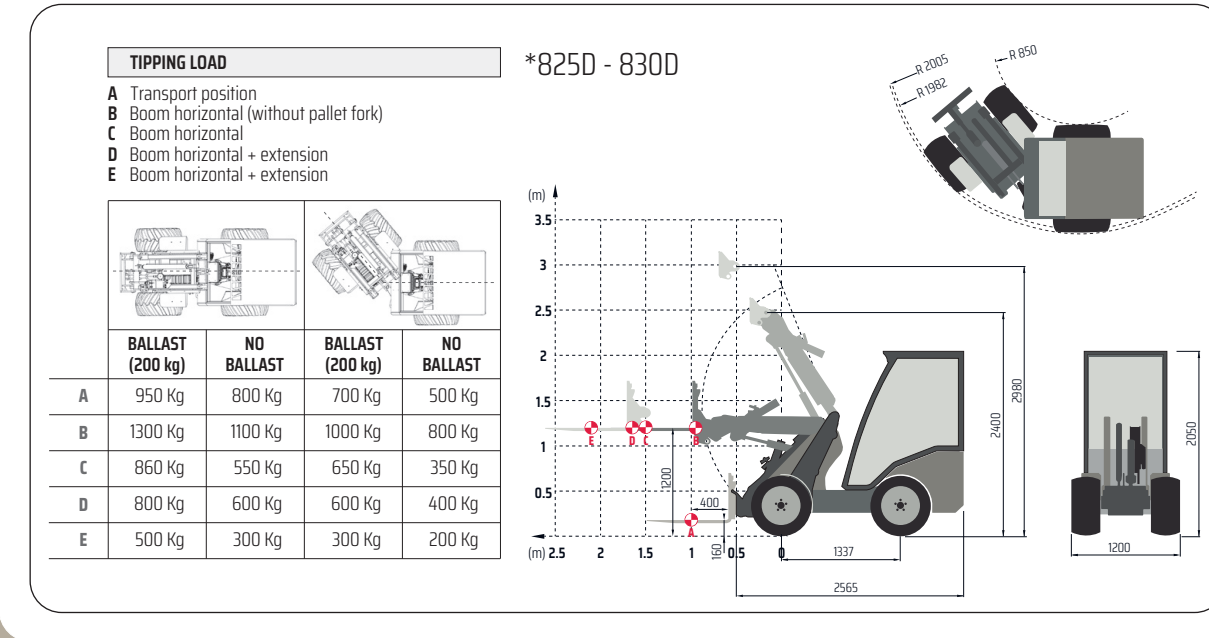

LOADING DIAGRAMS



WHEELS

SKID	ALL-TRAC	TRACTOR	TURF
23X8.50-12 23X10.50-12 26X12.00-12	8PR 300/60X12	23X8.50-12 23X10.50-12 26X12.00-12	23X8.50-12 23X10.50-12 24X13.00-12 26X12.00-12 26.5X14.00-12

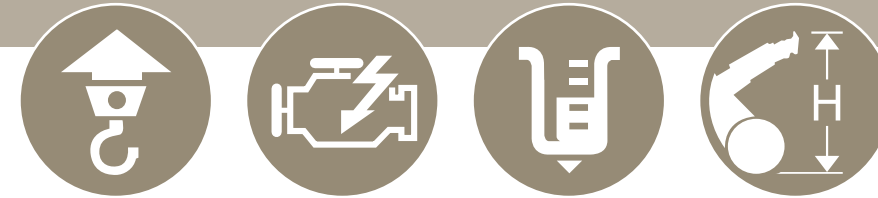

* with counterweights

<input type="checkbox"/> CAST 820D	1150 kg*	20 HP @ 3600 rpm	30 lt/min	2980 mm
<input type="checkbox"/> CAST 825D	1300 kg [B]*	26 HP @ 3000 rpm	42 lt/min	2980 mm
<input type="checkbox"/> CAST 830D CARBON	1300 kg [B]*	26 HP @ 2600 rpm	46 lt/min	2980 mm



CASTGROUP

CAST GROUP S.r.l.
 Via A. Meucci, 18 30035 Mirano VE Italia
 ph.+39 041 5701827- fax +39 041 5726786
 info@cast-group.it | www.cast-group.it



PL-800 series-EN_09/2022 - A0000000029

Data contained in this document is subject to change without notice and/or modification. Cast Group reserves the right to modify its products without obligation to communications. The images in this document are only a demonstrative purpose.



800 SERIES

- CAST 820D
- CAST 825D
- CAST 830D CARBON

CASTLOADERS.IT

800 SERIES



Electronic display with warning lights indicating faults, engine, hydraulic oil gauge, and electric floating system.



Tilt adjustment of the steering column.



5- function Joystick is standard on 820D and 825D. Ergonomic 11- function Joystick is standard on 830D Carbon.



Telescopic boom height up to 2980mm, the highest of its line.



Maximum speed: Up to 16 km/h (830D Carbon).



The side Safety Gate is supplied as an option and is available on all 800 Series models.

SILENT BLOCK

Safety and comfort.

The Silent Block device has been designed to ensure greater protection from vibrations and to cushion the blows caused by working on uneven ground, ensuring greater driving comfort and extending the life of the machine.



The 800 series is characterized by a design with a strong personality. Thanks to its low structure center of gravity the vehicle remains stable on all types of ground and offers the operator excellent visibility and maneuverability. Heated cabin available upon request. All models are equipped with the proven and reliable Kubota diesel engines. In addition, the electric differential lock, the ROPS / FOPS protection structure, the telescopic boom are supplied as standard. All models can be equipped (optional) with a soundproofed and heated cab. The selflevelling is standard on the 825D and 830D Carbon models.

800 series Technical specifications

	820D	825D	830D CARBON
<input type="checkbox"/> Engine data (Standard)			
Manufacturer: Kubota	✓	✓	✓
Diesel engine type	D722	D1105	D1305
Cylinders	3	3	3
kW	14,9	18,7	21,7
Displacement cc	719	1123	1261
Cooling system: Water	✓	✓	✓
Emissions standard level	#	#	III A
RPM	3600	3000	2600
<input type="checkbox"/> Electrical system			
Operating voltage: 12 V	✓	✓	✓
Alternator: 40 (65) A	✓	✓	✓
<input type="checkbox"/> Weights			
Weight (standard) kg	1100	1140	1170
Lifting capacity kg [B]*	1150	1300	1300
Max Pull force kg	800	800	800
Breakout force kg*	1150	1150	1150
<input type="checkbox"/> Vehicle data			
Joystick (11- function)	OPT	OPT	11ERG
Cab (optional)	✓	✓	✓
Electric differential lock	✓	✓	✓
Rops/Fops protection	✓	✓	✓
Telescopic boom	✓	✓	✓
Selflevelling	OPT	✓	✓
Speed km/h	10	12	16
Fuel tank capacity: 14 l	✓	✓	✓
Hydraulic oil tank capacity: 21 l	✓	✓	✓
<input type="checkbox"/> Drive			
Type of drive: Direct Drive 4WD Hydrostatic transmission	✓	✓	✓
Traction drive	✓	✓	✓
<input type="checkbox"/> Noise values			
Average sound power level: LwA 99 dB(A)	✓	✓	✓
Guaranteed sound power level: LwA 101 dB(A)	✓	✓	✓
<input type="checkbox"/> Wheels			
Tractor	23x8.50-12	23x10.50-12	26x12.00-12

* with counterweights

